

WCC 310 & WCC 320 UL Standard versions

Installation instruction

UL MotorController

(Version 1905 – for firmware from version 1.13 (motorline card))



Save this installation instruction to the end user

US +1 650 360 5414
Other markets +45 4567 0300

info.us@windowmaster.com
Info.dk@windowmaster.com

www.windowmaster.com

1	Safety information	3
1.1	Safety	3
1.2	120V AC	3
1.3	Application	3
1.4	Cable routing and electrical connection	3
2	Structure of the MotorController	4
3	Variants of MotorControllers	4
3.1	MotorController versions	5
3.2	Max numbers of actuators per motor line and MotorController	5
4	Accessories and spare parts	6
5	Technical data	6
6	Mounting	7
7	Installation	7
7.1	Cable routing	7
7.2	Cables into housing	7
7.3	Connection of safety earth wire and 120V AC	7
7.4	Installation of the ventilation keypad	7
7.5	Assembly instructions	8
8	Cable dimensioning	8
8.1	Max. cable Length	8
8.1.1	Formula for the calculation of the maximum actuator cable length	8
8.1.2	Max cable length – $\pm 24V$ standard actuators	9
8.1.3	Max cable length – actuators with MotorLink [®]	9
9	Cable plan for connection to WCC 310 / 320 Standard version	10
10	Description of cards and mains connection	11
10.1	WCC connection to mains and power supply units – WCA 3P3, WCA 3P5 and WCA 3P6	11
10.2	Motor line card WCA 3M4 and WCA 3M8	12
10.3	Input card – WCA 3KI	14
10.4	Power supply card – WCA 3P6	16
11	Configuration of the MotorController	16
12	Fault detection via LED	16
12.1	Fault detection on the MotorController	16
13	Hardware error	17
14	Commissioning and test run	17
14.1	The MotorController is completely installed, without the operating voltage applied	17
14.2	With mains voltage	17
14.3	Ventilation keypad	17
14.4	Wind/rain detector	17
15	Maintenance	18
15.1	Maintenance agreements	18
15.2	Replacement 3M4, 3M8 and 3KI card	18
16	Declaration of Conformity	18

1 Safety information

1.1 Safety

Only allow correspondingly trained, qualified and skilled personnel to carry out installation work.

Reliable operation and the avoidance of damage and hazards are only guaranteed if installation and settings are carried out carefully in accordance with these instructions.

There may be personal danger by electrically operated windows:

- the forces occurring in the automatic mode can be such that parts of the body could get crushed
- when opened, actuators (spindles) could protrude into the room

For this reason, measures have to be taken prior to starting up the actuators, which exclude the danger of injury.

For safety reasons we recommend to install opening restrictors on bottom-hung windows.

In the event that windows are subjected to rain and/or high wind loads, we recommend connecting a wind/rain sensor to the MotorController for the automatically closing of the windows.

The MotorController is to be located in a safe place, protected from the effects of fire and smoke.

The MotorController is to be surface mounted.

The MotorController is to be supplied with 120V AC .

The manufacturer does not assume any liability for possible damage resulting from inappropriate use.

1.2 120V AC

120V AC can cause death, severe injury or considerable damage to assets.

The connection of the MotorController is reserved for qualified personnel.

Disconnect all poles of the MotorController from the supply voltage prior to opening, installation or assembling.

Installation and use according to the national regulations.

1.3 Application

The MotorController is exclusively designed for the automatic opening and closing of windows, flaps or doors.

Always check that your system meets the valid national regulations.

Pay particular attention to the opening cross section, the opening time and opening speed.

The cable cross sections depend on the cable length and current consumption (amperage).

1.4 Cable routing and electrical connection

Fuse the 120V AC power supply cable separately on site.

Cable routing and connection - adhere to national regulations.

Establish the cable types, if necessary, with the local approval bodies.

Do not conceal flexible cables.

Junction box must be accessible for maintenance purposes.

Disconnect all poles of the mains voltage prior to starting maintenance work or making changes to the system.

Secure the system to prevent unintentional switching on again.

Route all low voltage cables (24V DC) separate from the power current cables.

Design cable types, lengths and cross sections in accordance with the technical information.

Cable specifications is a guide only, the overall responsibility resides with the electrical contractor on site.

Installation must be in accordance with the national electrical regulations.

2 Structure of the MotorController

Sizes & Versions

The WCC 310 and WCC 320 MotorControllers are available in two different versions namely a Standard and a Plus version. This installation instruction only deals with the Standard versions. Please see separate installation instruction for the Plus versions of WCC 310 and WCC 320.

Cards

Each MotorController contains a power supply unit (SMPS), either a WCA 3P3 or a WCA 3P5 for the 10A or 20A version respectively, as well as a 5W auxiliary power supply for wind / rain sensor. Aside from the power supply units the Standard version also includes a motorline card type WCA 3M4 or WCA 3M8 with 4 and 8 motor lines respectively and an input card WCA 3KI with 10 inputs. Additionally, the Standard version is also available in a version with fieldbus interface for KNX.

If additional motor lines, inputs or fieldbus connection is required a Plus version of the MotorController is necessary.

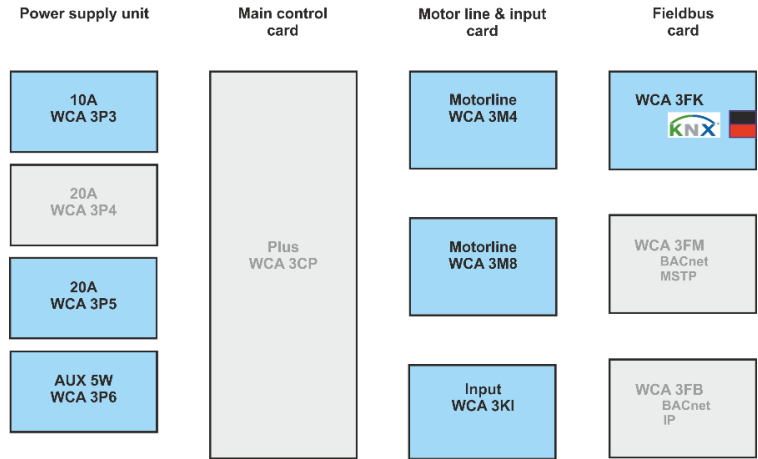

Motor groups and motor lines

A motor group consists of one or more motor lines and all the motor lines are operated simultaneously.

All motor lines on the motor cards (WCA 3M4 & WCA 3M8) can be configured for either a $\pm 24V$ standard actuators or MotorLink[®] actuators. A motor group can contain motor lines with both $\pm 24V$ standard actuators and MotorLink[®] actuators, whereas a motor line only can have $\pm 24V$ standard or MotorLink[®] actuators connected.

3 Variants of MotorControllers

Item composing						
WCC 3	xx	S	xx	xx	xxx	U3
						U3 = UL Std. 325 and product version number 3
						Fieldbus card " " = No fieldbus card KNX = Fieldbus card with interface to KNX
						Input card 10 = Input card with 10 inputs
						Motorline card 04 = Motor line card with 4 motor lines 08 = Motor line card with 8 motor lines
						MotorController version S = Standard
						MotorController size 10 = 10A 20 = 20A
MotorController series 3						

3.1 MotorController versions

Number of motor lines and other functions	Cards	Item number
WCC 310 versions		
Standard version 4 motor lines 10 keypads / inputs	1 x WCA 3M4 UL 1 x WCA 3KI	WCC 310 S 0410 U3
Standard version 4 motor lines 10 keypads / inputs KNX interface	1 x WCA 3M4 UL 1 x WCA 3KI 1 x WCA 3FK	WCC 310 S 0410 KNX U3
WCC 320 versions		
Standard version 8 motor lines 10 keypads / inputs	1 x WCA 3M8 UL 1 x WCA 3KI	WCC 320 S 0810 U3
Standard version 8 motor lines 10 keypads / inputs KNX interface	1 x WCA 3M8 UL 1 x WCA 3KI 1 x WCA 3FK	WCC 320 S 0810 KNX U3

3.2 Max numbers of actuators per motor line and MotorController

The table shows the maximum number of actuators, which can be connected per motor line and MotorController depending on the type of the actuators, MotorController and connected cards. The total power consumption of all the connected actuators must not exceed 10A or 20A depending on MotorController size.

	Per motorline		Per 10A MotorController		Per 20A MotorController	
	± 24V Actuators	MotorLink® Actuators	± 24V Actuators	MotorLink® Actuators (4 Motorlines)	± 24V Actuators	MotorLink® Actuators (8 Motorlines)
WMU 836-1	4	4	10	10	20	20
WMU 836-2	4	2	10	8	20	16
WMU 836-3	3	3	9	9	18	18
WMU 836-4	4	4	8	8	20	20
WMU 861-1	4	4	6	6	12	12
WMU 861-2	4	2	6	6	12	12
WMU 861-3	3	3	6	6	12	12
WMU 861-4	4	4	4	4	12	12
WMU 842 / 862 / 882-1	4	4	4	4	8	8
WMU 842 / 862 / 882-2	4	2	4	4	8	8
WMU 863 / 883-1	3	3	3	3	6	6
WMU 864 / 884-1	1	1	2	2	4	4
WMX 503 / 504 / 523 / 526-1	8	4	20	16	40	32
WMX 503 / 504 / 523 / 526-2	8	2	20	8	40	16
WMX 503 / 504 / 523 / 526-3	6	3	18	12	39	24
WMX 503 / 504 / 523 / 526-4	8	4	20	16	40	32
WMX 803 / 804 / 823 / 826-1	4	4	10	10	20	20
WMX 803 / 804 / 823 / 826-2	4	2	10	8	20	16
WMX 803 / 804 / 823 / 826-3	3	3	9	9	18	18
WMX 803 / 804 / 823 / 826-4	4	4	8	8	20	20
WMB 801/802*	max. 4A connected to WMB					
WMB 811/812 */**	4	2	10	8	20	16

* Do not exceed the total power consumption of the motor line

** When having two locking actuators per motor line, it must be one of each type: 1 x WMB 811 and 1 x WMB 812

4 Accessories and spare parts

Accessories	
Rain sensor	WLA 331
Rain/wind speed sensor	WLA 330
Spare parts	
10A power supply unit for WCC 310	WCA 3P3
20A power supply unit for WCC 320	WCA 3P5
5W 120 AC AC / 24V DC – 24V AUX supply for sensors	WCA 3P6
Motor line card with 4 motor lines incl cover	WCA 3M4 UL
Motor line card with 8 motor lines incl cover	WCA 3M8 UL
Input card with 10 inputs for e.g. comfort keypad incl. cover	WCA 3KI
3.15A fuse for motorline, 10 pcs (Littelfuse 807 13150440)	WCA 308

5 Technical data

Technical data		
Output current (nominal)	WCC 310: 10A / WCC 320: 20A	
Secondary voltage	Voltage 24V DC ($\pm 15\%$) Open circuit voltage (no load) 27.6V DC @ 20°C Ripple at max load max. 6% (3.5Vpp)	
AUX	24V DC, 0.23A	
Motor lines	WCC 310 0410: max 4, WCC 320 0810: max 8 a line can be either $\pm 24V$ standard motor line or MotorLink® motor lines	
Primary voltage	120V AC, 60Hz (85-264V AC, 47-63Hz)	
Power consumption	Idle consumption: WCC 310: min 1,1W ¹ , typ. 3W ² WCC 320: min 1,1W ¹ , typ. 3,5W ³ 1) min.: 1 actuator 2) typ.: 16 MotorLink® actuators + rain sensor 3) typ.: 32 MotorLink® actuators + rain sensor Max: WCC 310: At max load 305W WCC 320: At max load 605W	
Inrush current on primary site	70A<5ms. Max 3 x WCC 310/320 per 10 A supply group. Circuit breaker "C" characteristic.	
$\pm 24V$ change over time	min 500ms	
LED message OK and fault	Green (flickering) Yellow	CPU working fault
Connection cable	Actuators Other components Mains	flexible max 6 mm ² / solide max 10 mm ² Min. 22AWG, 300V, 80°C Listed / Recognized to UL 13 min 0.2mm ² / max 1.5mm ² Listed / Recognized to UL 13 Mains must be done per relevant Electrical Code. For permanent connection (rigid or flexible 1/2" conduit or equivalent) use the supplied 1/2" adaptor in the Knockout. Use 10, 12, or 14AWG conductors (same size).
Operating conditions	-5°C - +45°C, for indoor installation, the MotorController may not be covered	

Max actuator activation duration (duty cycle)	ED 40% (4min. per 10min.)
Number of motor lines	WCC 310: 4 x 10A motor line for $\pm 24V$ standard or MotorLink [®] motors WCC 320: 8 x 10A motor line for $\pm 24V$ standard or MotorLink [®] motors
Material	Metal housing for surface mounting
Colour	White (RAL 9010)
Size	355 x 320 x 76 mm (WxHxD)
Weight	WCC 310: 4kg WCC 320: 4.8kg
Protection class	IP 20
Certification	UL 325 and CSA C22.2 no 247-14 approved
Delivery	MotorController
Note	We reserve the right to make technical changes

6 Mounting

The MotorController is fixed to the wall through the $\varnothing 6\text{mm}$ holes in the back plane of the housing.

The MotorController is to be located in a safe place, protected from the effects of fire and smoke.

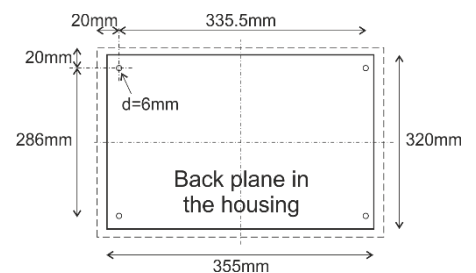

7 Installation

7.1 Cable routing

See also chapter 8 "Cable dimensioning" in this instruction. Do not reduce the cable cross sections specified in the cable lengths table.

All cables of the control (except the mains supply cable) carry 24V DC and have to be routed separate from the mains supply cable.

Adhere to the pertinent national and local regulations when routing the cables.

Ensure that the mains cable can be switched via an external or customer-supplied two-pole switch element or a switch element controlling all poles – see drawing.

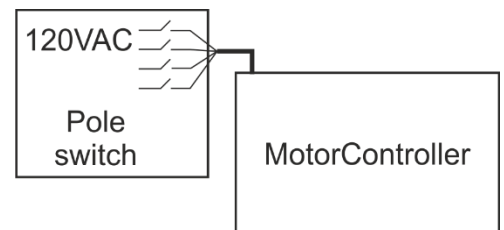

7.2 Cables into housing

All connection terminals (except the mains terminals) are of the plug-in type.

Connect the connection cables in accordance with the terminal plan. Ensure that the connections are made correctly.

Incorrect cable clamping, mixing up numbers or colours could lead to malfunctions of the control MotorController or of the external components.

Ensure that the electrical cables are always routed according to the valid national and local regulations.

7.3 Connection of safety earth wire and 120V AC

See chapter 10 'Description of cards', for further description.

7.4 Installation of the ventilation keypad

Ensure that the ventilation buttons are visible and well accessible. Do not install behind protruding walls, door panels or hidden by the building structure.

7.5 Assembly instructions

Always have assembly, installation, repair and maintenance of ventilation systems carried out by qualified personnel trained for this purpose.

Rules to be adhered to for setting up and installation

The following safety relevant rules have to be adhered to when planning the use of a ventilation system and its set-up and installation:

- The Provincial Building Ordinance of the provinces

Accident prevention regulations

Adhere to the general accident prevention regulations (APR), the APR for power operated windows and doors, and the installation rules in your country.

CAUTION:

Live components are directly accessible after opening the system housing.

Prior to inserting / removing cards disconnect to the MotorController from the mains supply.

- adhere to the installation instructions and your local energy providers
- select the place of installation such that free access is guaranteed for maintenance purposes
- select cables according to regulations in this instruction - take the calculation of the actuator supply cable lengths into account when laying the cables
- connect the cables in accordance with the drawings provided by the manufacturer
- route the cables in the building according to the regulations in this instruction
- check all system functions

8 Cable dimensioning

8.1 Max. cable Length

Maximum permissible cable length from the MotorController to the actuators taking into account the cable cross-section is shown in the following tables for “± 24V standard actuators“ and “MotorLink® actuators“.

8.1.1 Formula for the calculation of the maximum actuator cable length

Max. cable length = $\frac{\text{permissible voltage drop } 2V \text{ (UL)} \times \text{conductivity of copper(56)} \times \text{cable cross section in mm}^2 \text{ (a)}}{\text{max. actuator current total in amps (I)} \times 2}$

For both ±24V standard actuators and actuators with MotorLink® the cross section of the cable must not be less than 0.75mm² regardless of the result of above formula.

Maximum actuator cable length: Always measured from the MotorController to the last junction box + cable to the motor

Permissible max. voltage drop in the line: 2 Volt

Actuating current: Sum of all actuator power consumption per motor line

Note: do not use the PE wire / green/yellow wire in the motor cable for communication!

Example

Max actuator cable length with cable cross section 0.75mm² and actuator current 2A: $(2 \times 56 \times 0.75) : (2 \times 2) = \underline{21m}$

8.1.2 Max cable length – ±24V standard actuators

The actuator supply cable must have 2 wires. If cable monitoring is requested min. 3: 2 wires current carrying / 1 wire for monitoring.

±24V standard Actuators						
Do not use the PE wire / green/yellow wire!						
cable cross section [a]	3 wire 0.75mm²	3 wire 1.50 mm²	5 wire 1.50 mm² 2 wire parallel	3 wire 2.50 mm²	5 wire 2.50 mm² 2 wire parallel	3 wire 4.00 mm²
Total actuator current [I]						
1A	42m	84m	168m	140m	280m	224m
2A	21m	42m	84m	70m	140m	112m
3A	14m	28m	56m	47m	93m	75m
4A	11m	21m	42m	35m	70m	56m
5A	8m	17m	34m	28m	56m	45m
6A	7m	14m	28m	23m	47m	37m
7A	6m	12m	24m	20m	40m	32m
8A	5m	11m	21m	18m	35m	28m
9A		9m	18m	15m	31m	25m
10A		8m	16m	14m	28m	22m
20A		4m	8m	7m	14m	11m

8.1.3 Max cable length – actuators with MotorLink®

The actuator supply cable must have 3 wires: 2 wires current carrying / 1 wire for communication.

When a 5 wire cable is used for MotorLink®

It is not recommended to use parallel-wire.

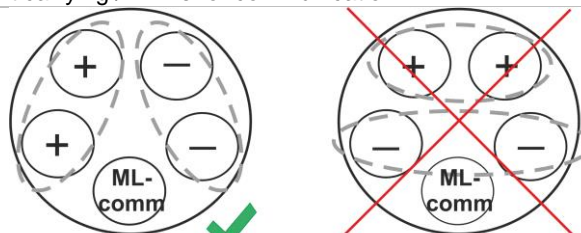

ML-comm = MotorLink® communication

When using actuators with MotorLink® the max cable length is 50m regardless of the result of the above mentions formula.

Actuators with MotorLink®						
Do not use the PE wire / green/yellow wire!						
cable cross section [a]	3 wire 0.75mm²	3 wire 1.50 mm²	5 wire 1.50 mm² 2 wire parallel	3 wire 2.50 mm²	5 wire 2.50 mm² 2 wire parallel	3 wire 4.00 mm²
Total actuator current [I]						
1A	42m	50m				
2A	21m	40m	50m			
3A	14m	28m	50m	47m	50m	
4A	11m	21m	42m	35m	50m	
5A	8m	17m	34m	28m	50m	45m
6A	7m	14m	28m	23m	47m	37m
7A	6m	12m	24m	20m	40m	32m
8A	5m	11m	21m	18m	35m	28m
9A		9m	18m	15m	31m	25m
10A		8m	16m	14m	28m	22m
20A		4m	8m	7m	14m	11m

9 Cable plan for connection to WCC 310 / 320 Standard version

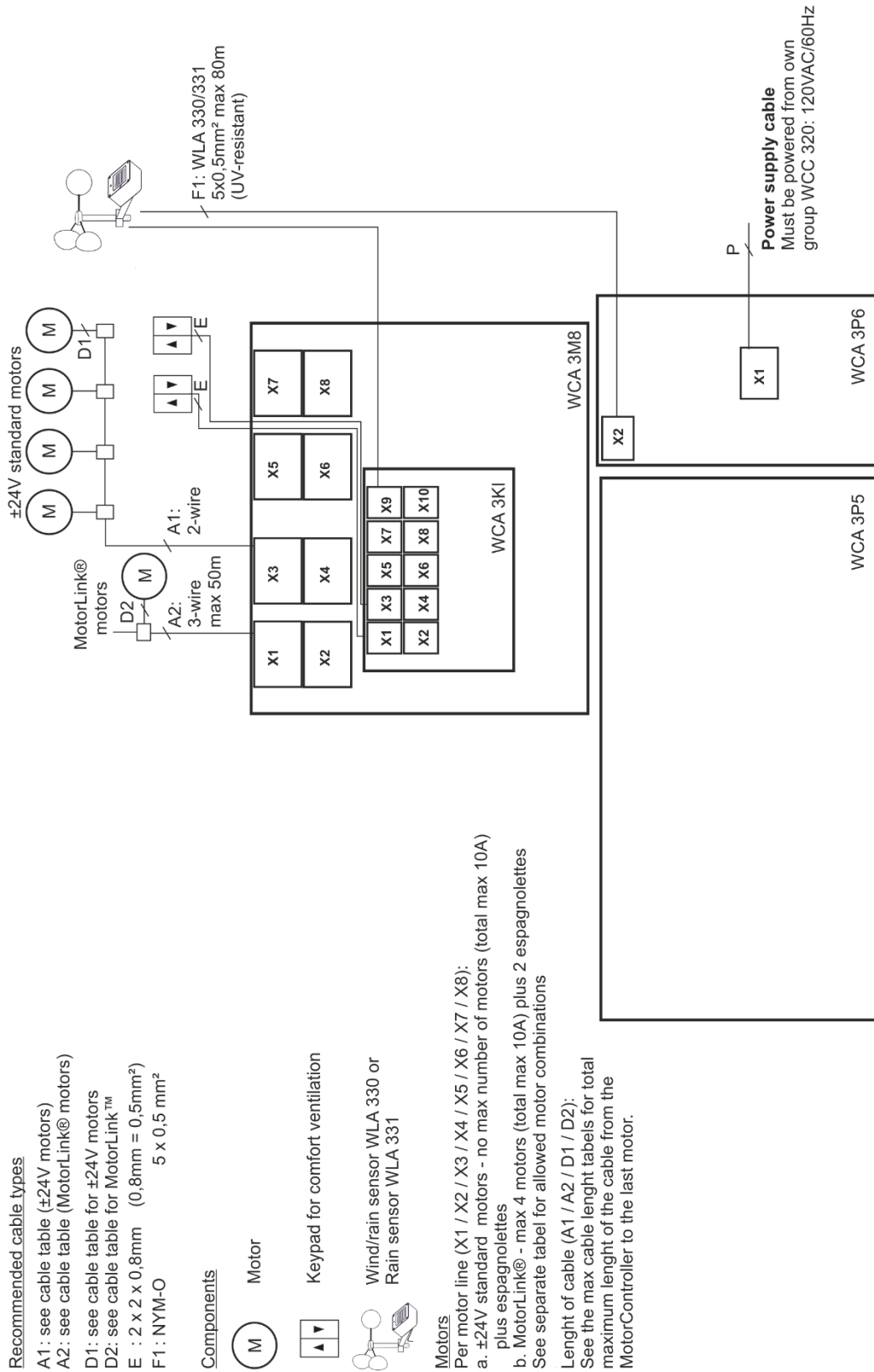

Above connection plan shows a WCC 320 MotorController

10 Description of cards and mains connection

Each MotorController includes a main power supply unit (SMPS), an auxiliary power supply (AUX), a motor line card and an input card.

The size of the power supply unit determines the number and/or types of actuators, which can be connected to the MotorController. See table with overview of max number of allowed actuators per motor line/ MotorController (chapter 3.2).

10.1 WCC connection to mains and power supply units – WCA 3P3, WCA 3P5 and WCA 3P6

The MotorController WCC 310, is supplied with a 305W SMPS power supply – WCA 3P3.
The MotorController WCC 320, is supplied with a 605W SMPS power supply – WCA 3P5

The power supply is, regardless of size, placed in the bottom of the MotorController beneath the motor line and input card.
An AUX – WCA 3P6 – to which mains is connected, is located to the right of the power supply.

Outlet to mains is in the top of the MotorController.

The MotorController is grounded by means of protective earth via the green screw next to WCA 3P6.

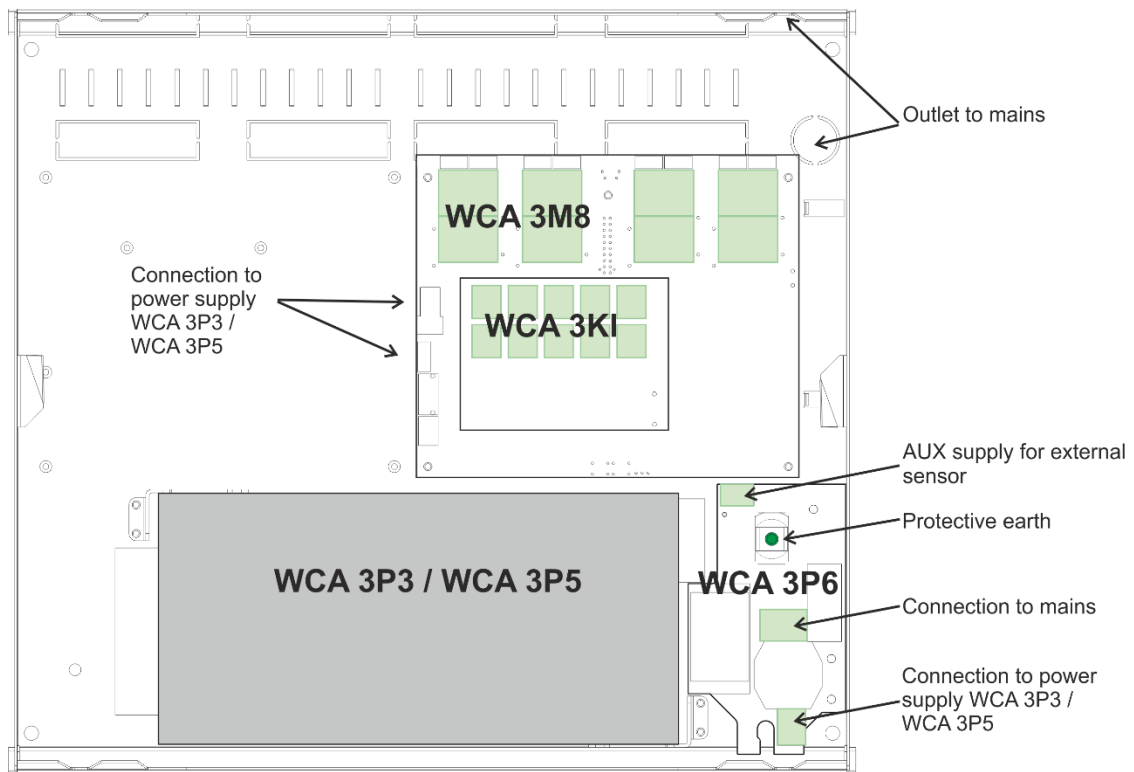

10.2 Motor line card WCA 3M4 and WCA 3M8

The motor line cards WCA 3M4 and WCA 3M8, allows connection of 4 and 8 motor lines respectively either $\pm 24V$ standard or MotorLink[®].

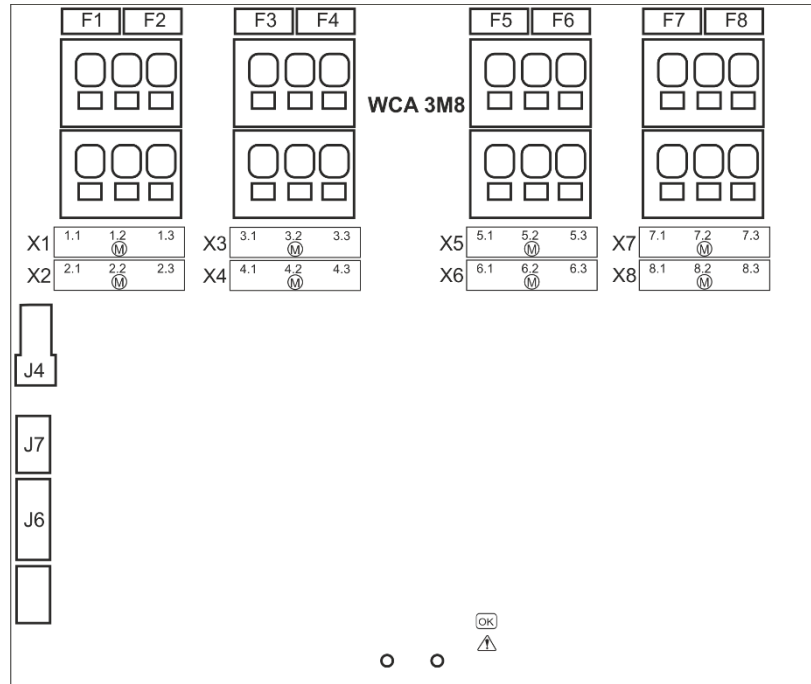

X1	1.1 24V / 0V 1.2 MotorLink 1.3 0V / 24V	} Motorline	X7	7.1 24V / 0V 7.2 MotorLink 7.3 0V / 24V	} Motorline
X2	2.1 24V / 0V 2.2 MotorLink 2.3 0V / 24V	} Motorline	X8	8.1 24V / 0V 8.2 MotorLink 8.3 0V / 24V	} Motorline
X3	3.1 24V / 0V 3.2 MotorLink 3.3 0V / 24V	} Motorline	F1-F8	Fuse 3.15A	
X4	4.1 24V / 0V 4.2 MotorLink 4.3 0V / 24V	} Motorline	J4	Connection to power supply	
X5	5.1 24V / 0V 5.2 MotorLink 5.3 0V / 24V	} Motorline	J6	Connection to input expansion module (WCA 3K1)	
X6	6.1 24V / 0V 6.2 MotorLink 6.3 0V / 24V	} Motorline	J7	Connection to power supply	
			○ ○	Reset / programming	

WCA 3M8 – motor line card with 8 motorline

S2 X1 – X8

WCA 3M4 and WCA 3M8 has 4 and 8 motor lines respectively for connection of either $\pm 24V$ standard or MotorLink[®] actuators.

$\pm 24V$ standard actuators

x.1 24V / 0V
x.2
x.3 0V / 24V

MotorLink[®] actuator

x.1 0V
x.2 ML Communication
x.3 24V

The number of actuators per motor line depends on the actuator type, the total power consumption of actuators connected to a motor line can max be 4A and the total max power consumption for both motor lines must not exceed 10A or 20A depending on type of MotorController.

Besides actuators also locking actuators (espagnolettes actuators) type WMB 801/802 and WMB 811/812 can be connected. The power consumption of the locking actuators are not to be included in the 10A / 20A as actuators and locking actuators do not run at the same time.

All actuators on the same motor line will run/be operated simultaneously.
All actuators on the same motor line must be of the same type.

Connection / cable diameter: flexible max 6 mm² / solid max 10 mm².
Cable length: see the chapter "Cable dimensioning".

Standard ±24V actuators

- Examples with 20A power consumption
 a) 8 pcs. WMX 826-1
 b) 4 sets of 2 pcs. WMX 826-2
 c) 4 pcs. WMU 861-1
 d) 2 sets of 2 pcs. WMU 842-2

Connection of variants of standard actuators on motor line X1

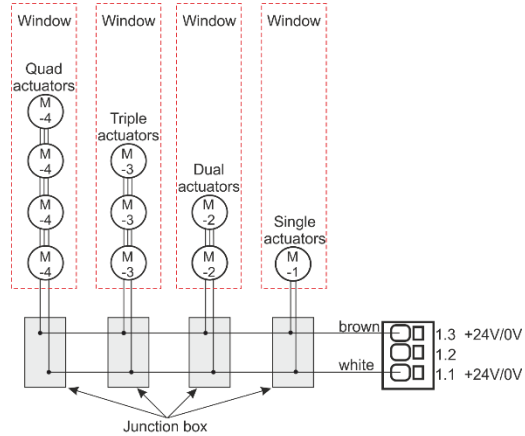

MotorLink® actuators

- Examples with actuators per motor line
 Ex. 1: 4 pcs. WMX 823-1
 Ex. 2: 2 pcs. WMX 842-2
 Ex. 3: 3 pcs. WMU 826-3

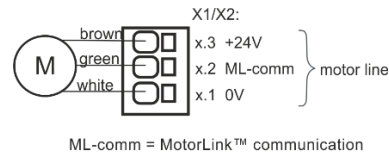

Allowed actuator combinations on a MotorLink® motor line

The eight motor lines on the motorline card can each be connected to one of the below shown combinations.

- 1 (single): one window with one single window actuator. Up to four windows each with one single window actuator can be connected
- 2 (double): one window with two double window actuators.
- 3 (triple): one window with three triple window actuators.
- 4 (quad): one window with four quad window actuators.

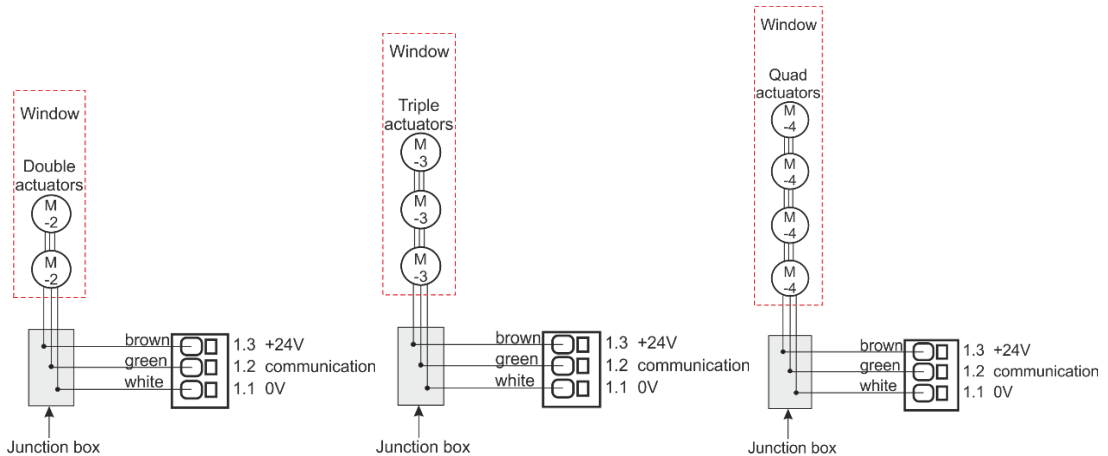
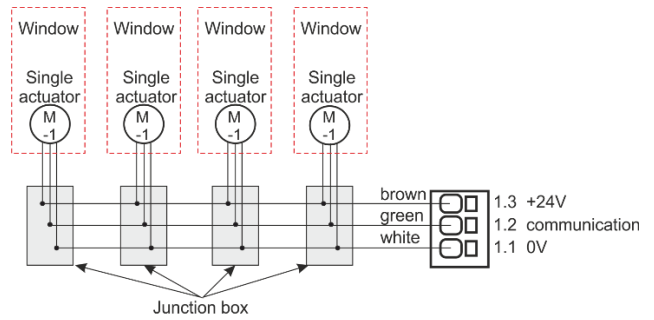

Cable monitoring

When using actuators with MotorLink®, the actuators with MotorLink® are monitored by data communication. When the team-size does not match, an error is indicated on the yellow diode.

F1 - F8	3.15A fuse (WCA 308)
J4	Connection for power supply
J6	Connection to input card WCA 3KI
J7	Connection to power supply

R / P	Reset / Programming (used for firmware updates)
LED	Shows the status of the MotorController Yellow = fault Green fast flickering = CPU working, Green constant = CPU communication stopped (possible reset or contact WindowMaster)

10.3 Input card – WCA 3KI

The input card allows connection of 10 keypads.

The WCA 3KI is connected to WCA 3M4 / WCA 3M8 via cable (J1 on WCA 3KI and J6 på WCA 3M4 / WCA 3M8).

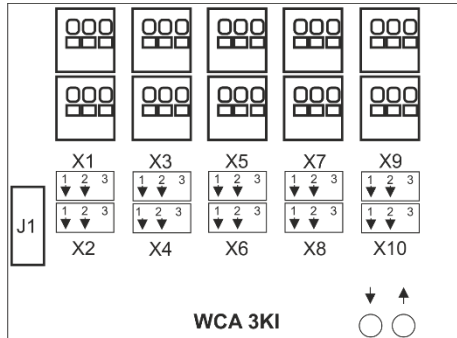

- | | | | | | |
|-----------|---|---------------------|------------|--|---------------------|
| X1 | 1.1 Open 1.1
1.2 Close 1.2
1.3 GND / 0V | } Comfort keypad #1 | X7 | 7.1 Open 7.1
7.2 Close 7.2
7.3 GND / 0V | } Comfort keypad #7 |
| X2 | 2.1 Open 2.1
2.2 Close 2.2
2.3 GND / 0V | } Comfort keypad #2 | X8 | 8.1 Open 8.1
8.2 Close 8.2
8.3 GND / 0V | } Comfort keypad #8 |
| X3 | 3.1 Open 3.1
3.2 Close 3.2
3.3 GND / 0V | } Comfort keypad #3 | X9 | 9.1 Close all / safety - weather
9.2 Momentary action / maintained action
9.3 GND / 0V | |
| X4 | 4.1 Open 4.1
4.2 Close 4.2
4.3 GND / 0V | } Comfort keypad #4 | X10 | 10.1 Open all
10.2 Close all
10.3 GND / 0V | } BMS / common |
| X5 | 5.1 Open 5.1
5.2 Close 5.2
5.3 GND / 0V | } Comfort keypad #5 | | | |
| X6 | 6.1 Open 6.1
6.2 Close 6.2
6.3 GND / 0V | } Comfort keypad #6 | | | |
- ↓ ↑ Close and open all windows
J1 Connection to actuator card

S3 X1 – X8 For connection of comfort keypads.

- Data
 x.1 Open x.1
 x.2 Close x.2
 x.3 GND / 0V

For WCC 310 0410 with only 4 motorlines input X5-X8 have no function.

With the default values are input:
 "Active" if the contact resistance is smaller than 2kΩ
 "Inactive" if the contact resistance is bigger than 3kΩ.
 Input has pull up current of approx. 0.8mA. (min 0.7mA, max 1mA)

Example: comfort keypad connected to input X3

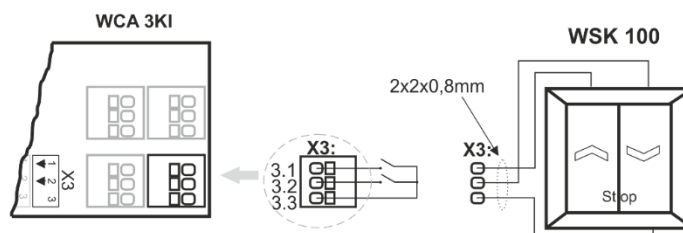

Long push (>500ms): open / close actuator, the actuator runs to end stop
 Short push: the actuator stops running

S3
X9

Connection of wind / rain sensors type WLA 330 or rain sensor WLA 331.
Wind / rain sensor is connected to both WCA 3KI and WCA 3P6 on X9 and X2 respectively.

Data

- 9.1 close all / safety (all motor groups)
- 9.2 Momentary action / maintained action
- 9.3 GND / 0V

Momentary action: the actuator only runs for as long as the keypad is activated.
Maintained action: the keypad is activated shortly and the actuator runs until the keypad is re-activated.

With the default values are input:

"Active" if the contact resistance is smaller than 4kΩ

"Inactive" if the contact resistance is bigger than 8kΩ.

For values between 4 and 8kΩ the result will depend on the supply voltage.

Input has pull up approx. 1mA. (min 0.7mA, max 1.4mA)

Connection of wind/rain and rain sensors

WLA 330 and WLA 331– the settings of the sensors are set on the sensor.

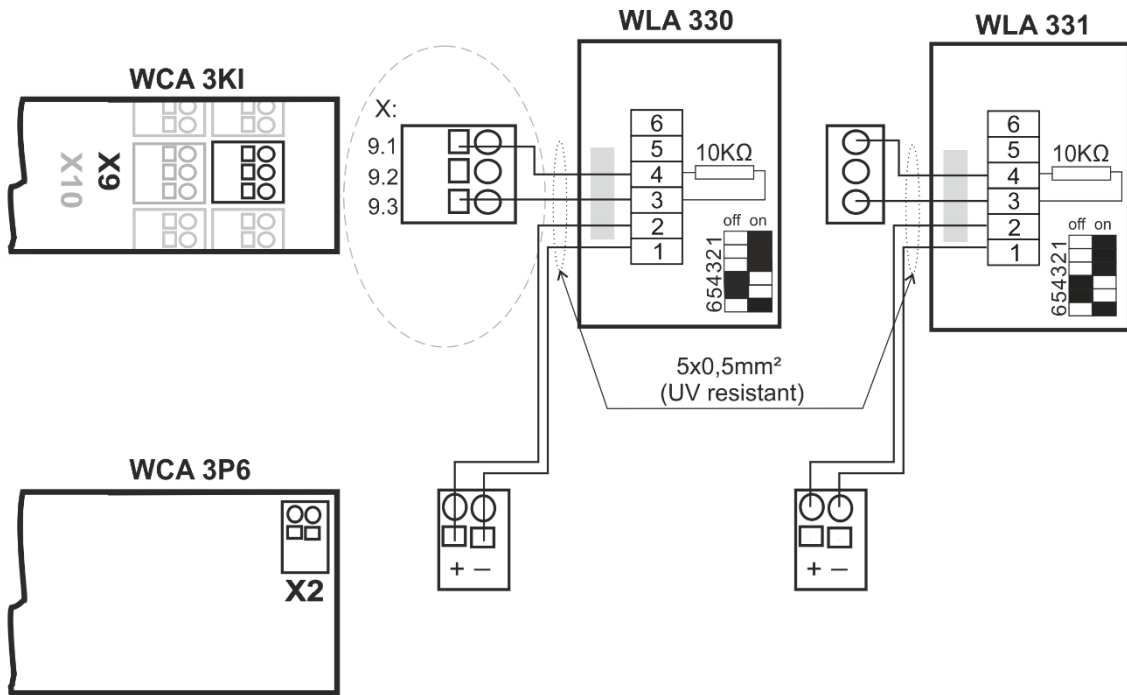
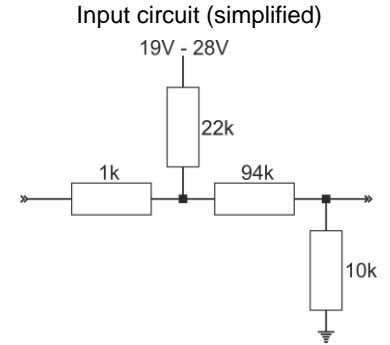

DIP switch 1-3 on WLA 330 must be set for wind speed tolerances. Please refer to the installations instruction for the WLA 330 for DIP switch settings.

If no wind / rain or rain sensor is connected to S3X9, a 10kΩ resistor must be connected between S3X9.1 and S3X9.3

S3
X10

- Data:
- 10.1 Open all
 - 10.2 Close all
 - 10.3 GND / 0V

X10.1 and X10.2 has lower priority than the individual inputs X1-X8.

X10.1 and X10.2 is blocked for a period of 30 min after X1-X8 has received a command.

↓ ↑

Close / open all windows. When pressed together right after power has been connected the MotorController configures / registers connected components.

J1

Connection for power supply

10.4 Power supply card – WCA 3P6

Mains and protective earth is connected to the MotorController via the power supply card.

On the standard version of the MotorController the power supply card enables connection of weather station or other sensor.

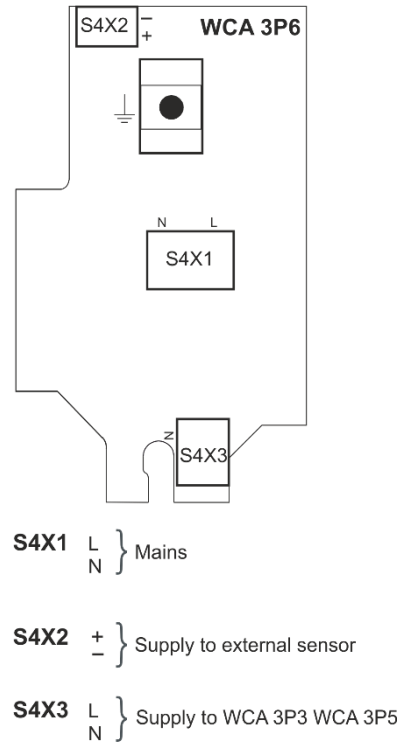

S4 X1	Connection to mains.
S4 X2	Connection to e.g. weather station. See "S3 X9" under "Input card – WCA 3K1" for description of connection of wind / rain sensor.
S4 X3	Connection to power supply WCA 3P3 (10A), or WCA 3P5 (20A)
	Protective earth (PE).

11 Configuration of the MotorController

The MotorController is configured by pressing the two keys "↑" and "↓" on the input card, at the same time for 10 seconds.

The MotorController must be configured

- After re-installation, changes, or change of actuators
- When / if MotorLink® actuators are connected
- If the cables have been moved
- When components are removed from the MotorController

Note, during reconfiguration actuator outputs can be activated in both directions.

If the yellow diode on the motor line card blinks after a configuration, an error has occurred in the configuration, see chapter "Fault detection via LED" for identification of errors.

Actuators are to be connected on the motor lines. ±24V standard actuators and actuators with MotorLink® can be connected to all motor lines, but a motor line can only be connected to one type of actuators – either ±24V standard or MotorLink® actuators. The MotorController will automatically detect the type of actuator, which is connected to the MotorController.

12 Fault detection via LED

12.1 Fault detection on the MotorController

In case of error on the MotorController, the yellow diode on the motor line card will blink and via blink sequence indicate an error message. Depending on the type of error message will consist of 2 or 3 blink sequences, separated by a seconds pause. The first blink in an error message has a duration of one second, and thereby indicating when the error message (1st blink sequence) begins. The remaining blinks of the error message has a duration of 0.5 seconds. The error message is repeated until the error has been rectified. Between 2 error messages there is a pause of 2 sec.

Example of an error message

"7 blinks – 1sec. pause – 2 blinks – 1 sec. pause – 1 blinks".

1. There is an error on a local input
2. The error is on input X10.5, to which a rain sensor might be connected
3. The error is due to no connection to the sensor.

If there are more errors on the MotorController simultaneously, they are shown with priority, i.e. the error message for the most critical error is shown first and repeated until rectified. Then the error message number 2 is shown and repeated as well until the error is rectified etc. Below table, list the most common errors.

Error message					
1. Blink sequence		2. Blink sequence		3. Blink sequence	
Number of blink	Error on	Number of blink	Error on or error type	Number of blink	Error type
1	System	1	Internal error (Watchdog reset)		
		2	Internal error (Program CRC)		
5	Actuator	1-8	X1-X8 (actuator output)	1	Actuator configuration – check the actuators, check the configuration, when using $\pm 24V$ standard actuators check the termination
				2	Expected number of actuators, the found and expected number of MotorLink® actuators does not match – check actuator connections
				4	Internal error
7	Local input	17	X9.1 (rain sensor)	1	Termination – check connection of sensor as well as termination
10	Power supply	1	Internal error		
		2	Mains – check connection		
		5	Internal error		

If other errors or an "Internal error" are indicated, please contact WindowMaster.

13 Hardware error

If there are any hardware error on the MotorController it will be indicated by the diodes (yellow diode is lit).

14 Commissioning and test run

In case of hardware error please see chapter 13 "Hardware error". To configure the MotorController press „↑“ and „↓“ (on the input card) at the same time for 10 seconds, see chapter 11.

We recommend that the software of the MotorController is updated the annual maintenance check!

14.1 The MotorController is completely installed, without the operating voltage applied

- a) Check all mechanical and electrical components for damage.
- b) Check all screw and plug connections for tightness and/or firm seating
- c) Check that all external components are installed:
 - 1) $\pm 24V$ actuators: check polarity

14.2 With mains voltage

Adhere to the relevant regulations!

Connect the mains cables and reapply the mains voltage.

14.3 Ventilation keypad

Closely observe the actuators during opening and closing. They must not be impaired in any position by the building structure. Observe that the actuator cables are not being subject to pulling or pinching. Check each ventilation keypad individually.

14.4 Wind/rain detector

- a) Open the actuators with the comfort ventilation keypads.
- b) Wet the rain sensor, the actuators will fully close.
- c) While the actuators are running, press the Open button at the keypad. The actuators must neither open nor stop!

Exception: If a manual override time (Man. operation after auto comm.).

If the start-up was successful, mount the door of the MotorController.

If the start-up was unsuccessful (error with one of the test run processes), please see chapter 10 "Description of cards". If necessary, check the wiring in accordance with the cable plan – see chapter 9 "Cable plan for connection to WCC 3xx".

15 Maintenance

The MotorController and ventilation system should be checked, serviced and, if necessary, repaired at least once per year by the manufacturer or an authorized partner

Remove all soiling from the units of the ventilation system. Check fastening and clamping screws for firm seating.

Carry out a test run of the entire system (see chapter 14 'Commissioning and test run').

Only have defective units repaired in our factory. Only install original spare parts.

Check the operational condition at regular intervals. We recommend a WindowMaster service contract is taken out to ensure the right function of the ventilation system.

We recommend that the software of the MotorController is updated the annual maintenance check!

The expected minimum lifetime for the MotorController is 10 years.

15.1 Maintenance agreements

WindowMaster offer maintenance agreements for the ventilation system. Contact our service department for further information: **telephone +44 1536 510990 or info@windowmaster.co.uk**

15.2 Replacement 3M4, 3M8 and 3KI card

1. Disconnect the 120V
2. Remove the old card
3. Insert the replacement card.
4. Turn on the 120V .
5. The system will be ready again after approx. 2 seconds.

16 Declaration of Conformity

The MotorController is manufactured and tested accordingly to the European requirements.

The total system is not to be put into service until a declaration of conformity for the total system has been made.

The "Declaration of Conformity" is supplied with the MotorController as separate documents.